

WIRELESS BROADBAND UDC 5800 UP/DOWN CONVERTER

# Operation & Installation Manual

---



## UDC 5800

### 2.4 GHz to 5.8GHz

### FREQUENCY UP/DOWN CONVERTER

TELETRONICS INTERNATIONAL, INC.  
2 CHOKE CHERRY ROAD  
ROCKVILLE, MD 20850

EMAIL: [sales@teletronics.com](mailto:sales@teletronics.com)  
TEL: 301.309.8500  
FAX: 301.309.8851

[www.teletronics.com](http://www.teletronics.com)

All Rights Reserved. No part or parts of this document may be reproduced, translated, stored in any electronic retrieval system, transmitted, in any form or by any means, electronic, mechanical, Photocopying, recording, or otherwise, without the prior written permission of the copyright holder.

---

# Table of Contents

---

MAJOR PARAMETERS .....	3
THE COMPLETE KIT CONTENTS.....	4
INSTALLATION .....	4
DC POWER INJECTOR CONNECTIONS, INDICATORS AND LABELS .....	5
UDC5800 CONNECTIONS, INDICATORS AND LABELS.....	5
SPECIFICATIONS.....	6
2.4/5.8 GHZ CHANNEL CONVERSION TABLE.....	6
LIMITED WARRANTY .....	7

---

# General Product Description

## ICON KEY

 General information

 Installation guide

 Quiz & Tip

UDC5800 is a bi-directional up-down RF frequency converter with amplifier designed to convert 2.4 GHz frequency band to 5.8 GHz to reduce congestion and interference in widely used 2.4 GHz band. Thus it allows the users to upgrade their existing 2.4 GHz systems to less occupied 5.8 GHz band and save equipment cost. It is installed in between the 2.4 GHz wireless radio equipment and 5.8 GHz antennas to convert the signal, compensate cable loss, increase radio transmit output power as well as improve its receiving sensitivity.

This product has a wide range of wireless applications in Wireless Local Area Network (WLAN), Wireless Local Loop (WLL), Wireless Internet Access (WIA), wireless modem connection with point-to-point, point-to-multipoint, where the Time Division Duplex (TDD) technology is used.



## Major Parameters

### UDC5800

Bi-directional, Half-Duplex TDD. Senses RF carrier from transmitter and automatically switches to transmit mode.

Its unique outdoor design enables it to be mast mounted and to operate in wide temperature range of  $-40$  to  $+75^{\circ}$  C.

Works with all brands of 2.4GHz radios without any adjustments. A highly linear product that delivers 500mW of 5.8 GHz signal for long-range applications. Outdoor unit delivers full power right at the

antenna feed.

Also available in OEM package with 5V DC input for use within an existing 2.4GHz radio.

- Frequency to Antenna: 5725MHz ~ 5850MHz
- Frequency to Radio: 2400MHz ~ 2500MHz
- Transmit Output Power: 500mW (+27dBm)
- Transmit Gain:  $10.5 \pm 2$ dB typical
- TX/RX switch time:  $< 10 \mu$ S
- RX Conversion Gain:  $10 \pm 2$ dB typical
- RX Noise Figure 4dB typical 5dB Max @70°C



### UDC5800

The unit operates automatically and no user adjustments are required

*The UDC does not work with a radio devices using separate bands for transmit and receive in a true full duplex mode.*

## The Complete Kit Contents

- An outdoor unit, the UDC5800
- DC injector
- Universal power supply, and
- Mounting hardware.

## Installation

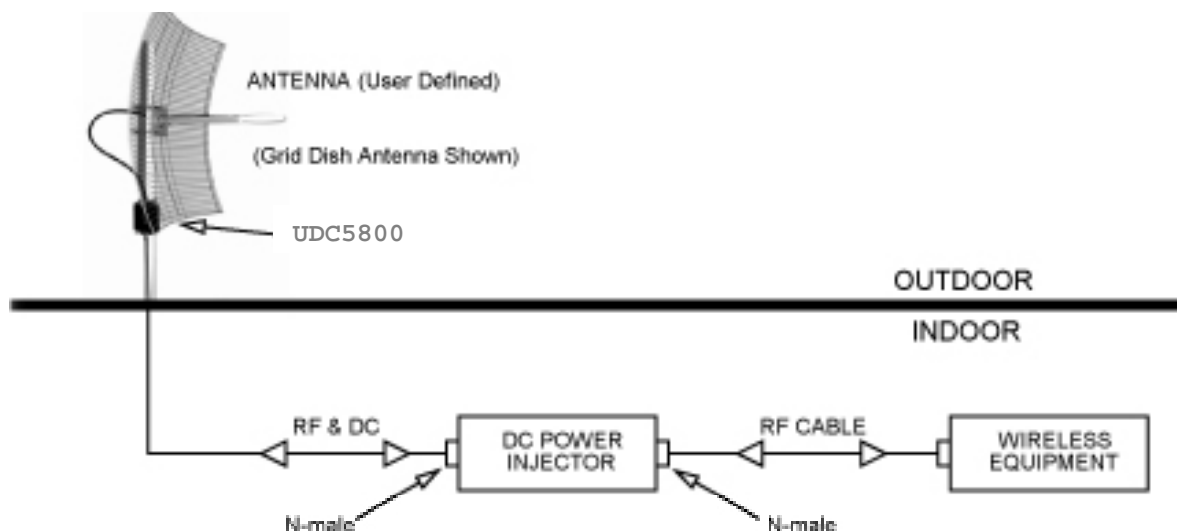

As shown in the above diagram power is carried to the UDC from DC Injector via RF cable. The DC injector is an indoor unit and requires weather protection. The UDC is installed at the antenna pole (or mast) with the U-bolt assembly. It is a weatherproof unit and designed to withstand the outdoor environment. Since the UDC5800 is built with lightning protection circuitry, it is extremely important to ground the whole unit. A grounding cable can be tightened directly to the U bolt. This would not only ground any lightning strike on the antenna but would also relieve it from any static built-up in the environment during bad weather.

Once the unit is installed and tested, all the N connectors must be waterproofed with electric tape or any other sealant.

### ⚠ Caution

1. The RF cable between the DC Injector and the UDC carries DC power, make sure it is NOT shorted to ground; OR DC Injector could be permanently damaged.
2. If this cable is accidentally connected to “To Antenna” connector on the UDC (since it has lightning protection with DC ground), the DC Injector could be permanently damaged.

## **DC Power Injector Connections, Indicators and labels**

The DC injector injects DC power into the RF cable and the power is carried to the UDC with the RF signal.

### **“To Radio”:**

This “N” Female connector is connected to the radio via a short jumper cable.

### **“To UDC”:**

This “N” Female connector connects to the UDC on the mast via the transmission cable.

LED: Green LED indicates DC power on.

### **DC Power Supply:**

The power supply provided with the unit is universal type, 110/220 V AC to 9 VDC . This has been tested for quality and performance. If a different 9 V DC adapter has to be used make sure it is provided with center positive 2.5mm jack.

## **UDC5800 Connections, Indicators and Labels**

### **“TO DC Injector”:**

This “N” Female connector is connected to the DC Power Injector via the transmission cable.

### **“TO Antenna”:**

This “N” Female connector connects to the antenna with a short length of coax cable.

LED:

This LED indicates three states:

Green	=	Transmit
Red	=	Receive
Orange	=	High speed Tx / Rx switching



## Specifications

Frequency Band to Antenna	5725~5850 MHz
Frequency Band to Radio	2400~2500 MHz
Local Oscillator Frequency	3328 MHz
Frequency Stability	2.5 ppm
Transmit Output Power (5.8GHz)	500 mW (27dBm)
Input Power (2.4GHz)	0.5 mW ~ 25 mW
Transmit Gain	14dB
Maximum Receiver Input Level	-20dBm
Noise Figure	4.0 dB Max.
Receive Gain	14 dB
Input Filter	5725~5850 MHz
Output Filter	2400~2500 MHz
Rx Switching Time	<1 $\mu$ S
LED indicators on UDC	Tx: Green, Rx: Red
Operating Temperature	-40 °C ~ + 70 °C
Power Supply	9.0V DC at 0.8 amp
RF Connector	Type N, Female
UDC5800 Dimensions	3.75" L X 6" W X 1.2" H
DC Injector Dimensions	3.5" L X 3" W X 1.18" H
UDC5800 Weight	2.0 lb
DC Injector Weight	0.4 lb

### ⚠ Caution

Do not exceed 200mW (+23 dBm) of input power to the UDC.



## 2.4/5.8 GHz Channel Conversion Table

802.11 Channel	2.4 GHz (MHz)	5.8 GHz (MHz)
1	2412	5740
2	2417	5745
3	2422	5750
4	2427	5755
5	2432	5760
6	2437	5765
7	2442	5770
8	2447	5775
9	2452	5780
10	2457	5785
11	2462	5790



## LIMITED WARRANTY

The UDC5800 is warranted to the original purchaser to be free from defects in materials and workmanship under normal installation, use, and service for a period of one (1) year from the date of purchase.

Under this warranty, Teletronics International, Inc. shall repair or replace (at its option), during the warranty period, any part that proves to be defective in material or workmanship under normal installation, use and service, provided the product is returned to Teletronics International, Inc., or to one of its distributors with transportation charges prepaid. Returned products must include a copy of the purchase receipt. In the absence of a purchase receipt, the warranty period shall be one (1) year from the date of manufacture.

This warranty shall be voided if the product is damaged as a result of defacement, misuse, abuse, neglect, accident, destruction or alteration of the serial number, improper electrical voltages or currents, repair, alteration or maintenance by any person or party other than a Teletronics International, Inc. employee or authorized service facility, or any use in violation of instructions furnished by Teletronics International, Inc.

This warranty is also rendered invalid if this product is removed from the country in which it was purchased, if it is used in a country in which it is not registered for use, or if it is used in a country for which it was not designed. Due to variations in communications laws, this product may be illegal for use in some countries. Teletronics International, Inc. assumes no responsibility for damages or penalties incurred resulting from the use of this product in a manner or location other than that for which it is intended.

**IN NO EVENT SHALL TELETRONICS INTERNATIONAL, INC. BE LIABLE FOR ANY SPECIAL, INCIDENTAL OR CONSEQUENTIAL DAMAGES FOR BREACH OF THIS OR ANY OTHER WARRANTY, EXPRESSED OR IMPLIED, WHATSOEVER.**

Some states do not allow the exclusion or limitation of special, incidental or consequential damages, so the above exclusion or limitation may not apply to you.

This warranty gives you specific legal rights, and you may also have other rights that vary from state to state.

Should you have any problems using it, call our service department at 301-309-8500.