

**TELETRONICS**  
INTERNATIONAL INC.

# **SMARTAMP™**

**BI-DIRECTIONAL POWER  
AMPLIFIER FOR 2.4 GHz, 1W Indoor**

## **User and Installation Manual**

---

TELETRONICS INTERNATIONAL, INC.  
2 CHOKE CHERRY ROAD  
ROCKVILLE, MD 20850

EMAIL: [sales@teletronics.com](mailto:sales@teletronics.com)  
TEL: 301.309.8500  
FAX: 301.309.8851

**[www.teletronics.com](http://www.teletronics.com)**

**Copyright ©2003**

**By**

**Teletronics International, Inc.**

**Patent Pending**

**FCC NOTICES**

**Electronic Emission Notice:**

This device complies with Part 15 of the FCC rules. Operation is subject to the following two conditions:

1. This device may not cause harmful interference.
2. This device must accept any interference received, including interference that may cause undesired operation.

**FCC Radiation Exposure Statement:**

This equipment complies with FCC radiation exposure limits set forth for an uncontrolled environment when installed as directed. This equipment should be installed and operated with fix-mounted antennas that are installed with a minimum of 2 meters of separation distance between the antenna and all persons body during normal operation.

---

All Rights Reserved. No part or parts of this document may be reproduced, translated, stored in any electronic retrieval system, or transmitted, in any form or by any means, electronic, mechanical, photocopying, recording, or otherwise, without the prior written permission of the copyright holder.

---

## Table of contents

<b>1. General Product Description</b>	<b>4</b>
<b>2. Background</b>	<b>4</b>
<b>3. Major Parameters</b>	<b>5</b>
<b>4. Salient Characteristics:</b>	<b>5</b>
<b>5. Installation:</b>	<b>6</b>
<b>6. DC Power Supply:</b>	<b>6</b>
<b>7. Amplifier Connections, Indicators and Labels:</b>	<b>7</b>
<b>8. Functioning:</b>	<b>7</b>
<b>9. Summary:</b>	<b>7</b>
<b>10. Specifications:</b>	<b>8</b>
General Specifications	8
Nominal Loss Characteristics For Different Cables	9
Decibels-Watts conversion Table	9
<b>11. Path Loss Calculation</b>	<b>10</b>
<b>12. FCC Certified Systems</b>	<b>10</b>
FCC ID: MFMSAMP24W	10
FCC ID: MFMSAMP24X	10
<b>13. Limited Warranty</b>	<b>11</b>

## 1. General Product Description

SMART Amplifier (SMARTAMP) is a bi-directional amplifier designed to match any advanced spread spectrum system, either direct sequence or frequency hopping, to extend the operating range of wireless equipment. It is provided in a wide range of frequencies, such as 900 MHz, 2400 MHz, or 5800 MHz. It works in Time-Division Duplex (TDD) mode that allows the radio device to share the antenna in different time intervals. SMARTAMP consists of an intelligent algorithm and Automatic Gain Controlled (AGC) circuits to maintain the output power and prevent transmit signal saturation. The input transmit power level is sensed by the Radio Frequency (RF) sensor and the gain is automatically adjusted to minimize the signal distortion so that the desired signal quality can be assured..

This product has a wide range of wireless applications in Wireless Local Area Network (WLAN), Wireless Local Loop (WLL), Wireless Internet Access (WIA), wireless modem connection with point-to-point, point-to-multipoint, where the Time Division Duplex (TDD) technology is used.

## 2. Background

In wireless applications, when longer operating range is required, the add-on antenna amplifier and DC injector set are often a choice. Because of different site layout and hardware configuration, it is almost impossible for amplifier manufacture to design the amplifier and fit all applications. Typically, in most applications, the interconnection cable could have different length from a few feet to a few hundred feet. Also, different radio modems have different output powers. Thus, the system installer must carefully measure the input RF power at the antenna amplifier and specify the gain of the amplifier in order to maintain the system performance. With different systems, different amplifiers are required. With this invention, the major difference as compared to other existing technology, is the “SMART function” - power level detection and automatic gain control circuit. With SmartAmp, the gain can be intelligently adapt to the input power level in a wide range and automatically further adjusted to accommodate the cable and connectors loss, by however length and configuration. The output power level is monitored and maintained intelligently; hence the desired performance can be achieved in all hardware configurations for TDD wireless applications irrespective of installation environment.

The table on the next page summarizes the difference between SMARTAMP and other TDD antenna-mount amplifier product.

**Differences Between Smart Amp and Other TDD Amplifier**

	<b>SMARTAMP</b>	<b>Other TDD Amplifier</b>
Transmit gain	Intelligent self	Fixed

	adjusted	
Transmit power level	Maintained	Varies, depending on input power level
Transmit signal distortion	Minimized at all time	Much worse at high input power levels
Input power range requirements	Wide range accepted	Designed for narrow range only

### 3. Major Parameters

Smart Amplifier fitted with a Low Noise amplifier (LNA) and together with its unique bi-directional features is fully capable of enhancing the coverage area of 2.4 GHz radio signals by amplifying transmitted and received signals.

The Smart Amp ensures a seamless RF link in most installations with long cable losses. Its unique outdoor design enables it to be mast mounted and to operate in wide temperature range of  $-40$  to  $+75$  C.

**2.5 mW (+4 dBm) input to the amplifier delivers 1Watt output. For signal input values greater than 4 dBm the Smart Amplifier attenuates the signal accordingly and keeps the output at 30 dBm. Up to 200 mW of power may be safely applied directly to the amplifier input without causing any damage.**

**The complete set includes:**

1. An indoor unit, the SmartAmp
2. Universal power supply (110~240VAC to 9 V DC)

### 4. Salient Characteristics:

- Complete One Year Warranty on parts and labor.
- Automatic gain control to minimize the signal distortion
- Wide Transmit input levels (2mW to 200mW)
- Low noise amplifier with system noise figure 3.5dB
- Universal 110/220VAC auto switching AC adapter
- Bi-color LED on SmartAmp for transmit and receive.
- SmartAmp equipped with Lightning Protection if grounded properly.
- Industry standard "N" Connectors on both ends.
- **Made in USA**



## **5. Installation:**

The SmartAmp is a stand-alone unit designed for installation by professional radio installers.

### **Typical Installation:**

The amplifier can be installed indoor on a flat surface using the tapped holes on the bottom of the amp. By using RF cables It is simply connected with the radio on one end and antenna on the other. In this indoor unit is powered by a 9V DC power adapter. If used with an outdoor antenna, its recommended to utilize the built-in lightning protection by grounding the amplifier enclosure from any of its four mounting flanges. This would not only ground any lightening strike on the antenna but would also relieve it from any static buildup in the environment during bad weather.

## **6. DC Power Supply:**

The power supply provided with the unit is universal type, 110/220 V AC to 9 VDC converter. This has been tested for quality and performance. If a different 9V DC adapter has to be used make sure it is provided with center positive 2.5mm jack and minimum of 1.2 Amp rated capacity.

## 7. Amplifier Connections, Indicators and Labels:

### “TO Radio” Connection:

This “N” Female connector is connected to the power output of radio device via an RF cable.

### “TO Antenna” Connection:

This “N” Female connector connects to the antenna with a short length of coax cable.

### LED:

This LED indicates three states:

Green	=	Transmit
Red	=	Receive
Orange	=	High speed Tx / Rx switching

## 8. Functioning:

This amplifier is designed for 2.4 GHz radios using Time Division Duplex (TDD) mode of operation. It is equipped with a high speed Tx / Rx switch, that detects transmit signal and switches to transmit mode within 600 ns. In the absence of any transmit signal the unit stays in receive mode. If used with a radio devices using separate bands for transmit and receive in a true full duplex mode, the amplifier would not work.

## 9. Summary:

This manual describes how SmartAmp as a product exploits the automatic gain control by detecting the input power level, automatically adjusting its gain and maintaining the output power to a specified level while minimizing the signal distortion and maximizing and transmission distance. This product has a wide range of wireless applications in Wireless Local Area Network (WLAN), Wireless Local Loop (WLL), Wireless Internet Access (WIA), wireless modem connection with point-to-point, point-to-multipoint, where the Time Division Duplex (TDD) technology is used.

Should you have any problems using it, call our service department at 301-309-8500.

## 10. Specifications:

### General Specifications

Operating Range	2400 ~ 2500 MHz
Operating Mode	Bi-directional TDD
Transmit Output Power	+30 dBm ( 1Watt )
Transmit Input Power	3 dB min, 23 dB max
Transmit Gain	Automatically adjusts up to 26 dB
Receive Gain	16 dB
Frequency Flatness	$\pm 1.0$ dB
Noise Figure	3.5 dB
Lightening Protection	Direct DC ground at antenna port
DC Surge Protection	At 9 V DC input
LED indicators on Amp	Tx: Green, Rx: Red
Operating Temperature	-40 °C ~ + 75 °C
Power Supply	9 V DC at 1.1 Amp
RF Connector	Type N, Female

**CAUTION:** Do not exceed 200mW (+23 dBm) of input power to the amplifier.

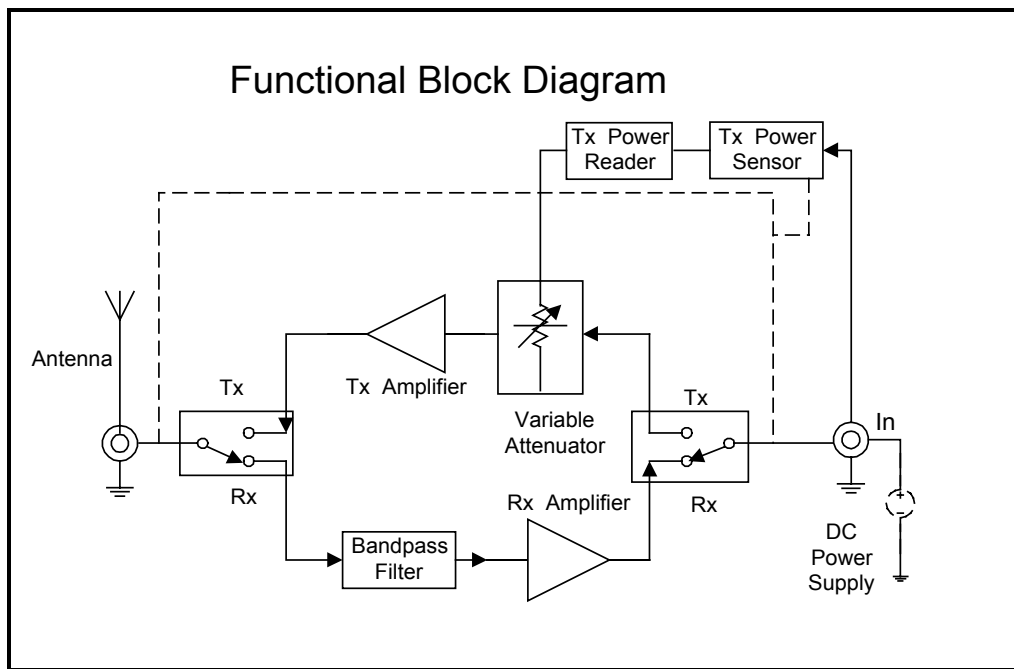



<b>Nominal Loss Characteristics For Different Cables (decibels per hundred feet at 2.5 GHz)</b>	
LMR-400	6.8 dB
LMR-500	5.5 dB
LMR-600	4.4 dB
LMR-900	3.0 dB
LMR-1200	2.27 dB

**Decibels-Watts conversion Table**

<b>dB</b>	<b>mW</b>
0	1.0
1	1.3
2	1.6
3	2.0
4	2.5
5	3.2
6	4.0
7	5.0
8	6.3
9	7.9
10	10.0
11	12.6
12	15.8
13	20.0
14	25.1
15	31.6
16	39.8
17	50.1
18	63.1
19	79.4
20	100.0
21	125.9
22	158.5
23	199.5
24	251.2
25	316.2
26	398.1
27	501.2
28	631.0
29	794.3
30	1000.0

<b>dB</b>	<b>Watts</b>
31	1.3
32	1.6
33	2.0
34	2.5
35	3.2
36	4.0
37	5.0
38	6.3
39	7.9
40	10.0
41	12.6
42	15.8
43	20.0
44	25.1
45	31.6
46	39.8
47	50.1
48	63.1
49	79.4
50	100.0
51	125.9
52	158.5
53	199.5
54	251.2
55	316.2
56	398.1
57	501.2
58	631.0
59	794.3
60	1000.0
61	1258.9

## 11. Path Loss Calculation

Loss = 32.44 + 20 log f + 20 log d [where f = frequency in MHz and d= distance in km]

System Gain =Po (Tx power) + Gt (Tx antenna gain) + Gr (Rx antenna gain) - Mf (fade margin) -Ms (system margin) - Pr (minimum receive signal level)

## 12. FCC Certified Systems

### **FCC ID: MFMSAMP24W**

Radio: Cisco 352  
 Antenna: As shown in the table 1  
 Amplifier: Smartamp2400-1.0 (outdoor version)

<b>Antenna Type</b>	<b>Gain (dBi)</b>	<b>Min. Cable Length LMR400</b>	<b>Max. Cable Length LMR400</b>	<b>Max Cable Length LMR600</b>	<b>Point to Point/ Point to Multi Point</b>
ANT-O2405	5	3'	200 feet	300'	Point to Multi Point
ANT-O2408	8	10'	200 feet	300'	Point to Multi Point
ANT-P2412	12	10'	200 feet	300'	Point to Point
ANT-G2418	18	3'	200 feet	300'	Point to Point

### **FCC ID: MFMSAMP24X**

Radio: Cisco 352  
 Antenna: As shown in the table 1  
 Amplifier: Smartamp2400-1.0 (indoor version)

<b>Antenna Type</b>	<b>Gain (dBi)</b>	<b>Min. Cable Length LMR400</b>	<b>Max. Cable Length LMR400</b>	<b>Max Cable Length LMR600</b>	<b>Point to Point/ Point to Multi Point</b>
ANT-O2405	5	25'	200 feet	300'	Point to Multi Point
ANT-O2408	8	25'	200 feet	300'	Point to Multi Point
ANT-P2412	12	25'	200 feet	300'	Point to Point

### **13. Limited Warranty**

The SmartAmp is warranted to the original purchaser to be free from defects in materials and workmanship under normal installation, use, and service for a period of one (1) year from the date of purchase.

Under this warranty, Teletronics International, Inc. shall repair or replace (at its option), during the warranty period, any part that proves to be defective in material of workmanship under normal installation, use and service, provided the product is returned to Teletronics International, Inc., or to one of its distributors with transportation charges prepaid. Returned products must include a copy of the purchase receipt. In the absence of a purchase receipt, the warranty period shall be one (1) year from the date of manufacture.

This warranty shall be voided if the product is damaged as a result of defacement, misuse, abuse, neglect, accident, destruction or alteration of the serial number, improper electrical voltages or currents, repair, alteration or maintenance by any person or party other than a Teletronics International, Inc. employee or authorized service facility, or any use in violation of instructions furnished by Teletronics International, Inc.

This warranty is also rendered invalid if this product is removed from the country in which it was purchased, if it is used in a country in which it is not registered for use, or if it is used in a country for which it was not designed. Due to variations in communications laws, this product may be illegal for use in some countries. Teletronics International, Inc. assumes no responsibility for damages or penalties incurred resulting from the use of this product in a manner or location other than that for which it is intended.

**IN NO EVENT SHALL TELETRONICS INTERNATIONAL, INC. BE LIABLE FOR ANY SPECIAL, INCIDENTAL OR CONSEQUENTIAL DAMAGES FOR BREACH OF THIS OR ANY OTHER WARRANTY, EXPRESSED OR IMPLIED, WHATSOEVER.**

Some states do not allow the exclusion or limitation of special, incidental or consequential damages, so the above exclusion or limitation may not apply to you.

This warranty gives you specific legal rights, and you may also have other rights that vary from state to state.